

Model LS LVDT type extensometer

Compatible with

Tinius Olsen ST and
SL series of materials
testing systems

Gage lengths

12.5 to 50mm or
0.5 to 2inches

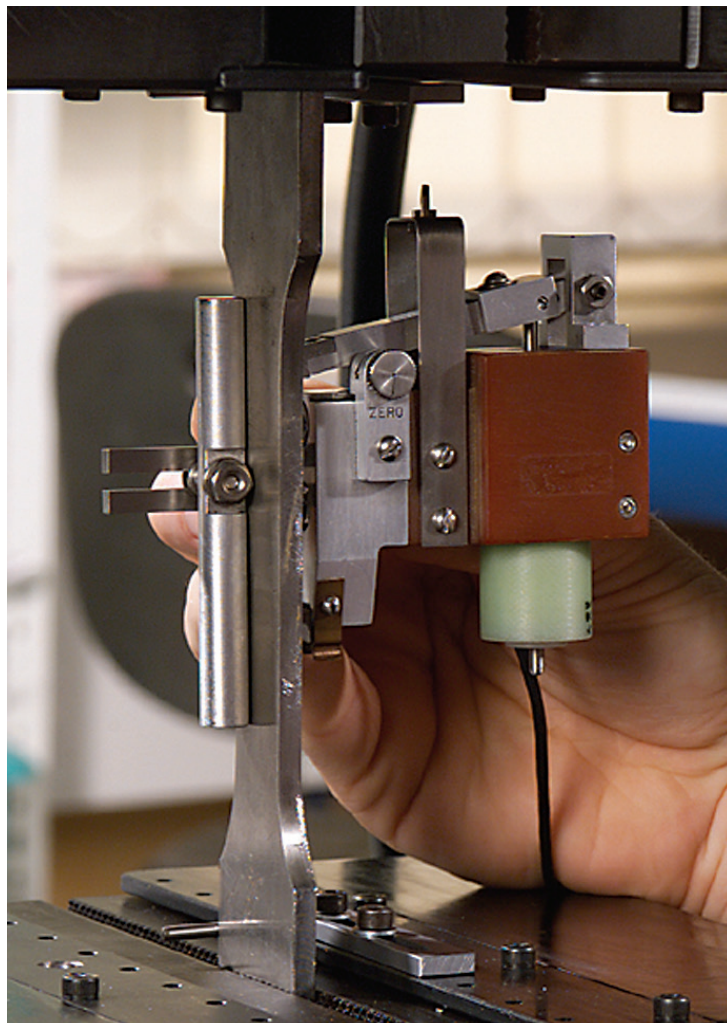

Extensometers measure strain, the change in length of a specimen divided by the original length (gage length) of the specimen. An extensometer measures strain by means of knife edges that contact the sample, one of which is fixed in its position, and the other which is located on a moveable arm.

On these models, the moveable arm is pivoted, one end is the knife edge and the other is attached to an armature that moves through an LVDT coil. Most of these extensometers can be adapted to your exact specimen holding needs by the options that are described on the back page, but in their standard form hold flat or round specimens from 1/16" to 5/8" (1.6 mm to 16 mm).

LS models - Imperial units

Model	Measuring range	Gage length	Calibrated ranges	Averaging	Film clamp	Breakway release	Sheet metal	Extension bracket	Pneumatic release
LS-8%-0.5 ³	8%	0.5in	8%, 4%, 2%						
LS-8%-1	8%	1in	8%, 4%, 2%	+	+	+	+		+
LS-50%-1	50%	1in	50%, 25%, 12.5%, 5% ¹ , 2% ²			+	+		+
LS-8%-1.4	8%	1.4in	8%, 4%, 2%	+	+	+	+		+
LS-50%-1.4	50%	1in	50%, 25%, 12.5%, 5% ¹ , 2% ²			+	+		+
LS-4%-2	4%	2in	4%, 2%, 1%	+	+	+	+	+	+
LS-10%-2	10%	2in	10%, 5%, 2.5%, 1% ¹	+	+	+	+	+	+
LS-20%-2	20%	2in	20%, 10%, 5%, 2% ¹		+	+	+	+	+
LS-50%-2	50%	2in	50%, 25%, 12.5%, 5% ¹ , 2% ²			+	+	+	+

LS models - Metric units

Model	Measuring range	Gage length	Calibrated ranges	Averaging	Film clamp	Breakway release	Sheet metal	Extension bracket	Pneumatic release
LS-8%-0.5 ³	8%	12.5mm	8%, 4%, 2%						
LS-8%-1	8%	25mm	8%, 4%, 2%	+	+	+	+		+
LS-50%-1	50%	25mm	50%, 25%, 12.5%, 5% ¹ , 2% ²			+	+		+
LS-8%-1.4	8%	35mm	8%, 4%, 2%	+	+	+	+		+
LS-50%-1.4	50%	35mm	50%, 25%, 12.5%, 5% ¹ , 2% ²			+	+		+
LS-4%-2	4%	50mm	4%, 2%, 1%	+	+	+	+	+	+
LS-10%-2	10%	50mm	10%, 5%, 2.5%, 1% ¹	+	+	+	+	+	+
LS-20%-2	20%	50mm	20%, 10%, 5%, 2% ¹		+	+	+	+	+
LS-50%-2	50%	50mm	50%, 25%, 12.5%, 5% ¹ , 2% ²			+	+	+	+

Notes

1. must have a 10:1 strain range
2. Optional fifth strain range required (25:1)
3. A counterbalance support must be used

Standard extensometers can be used at temperatures from -100 to 250 °F (-75 to 120 °C) or with modifications from -300 to 500°F (-185 to 260°C) denoted suffix T

TO order numbers

03081110

LVDT Extensometer; LSM-20%-50

Options for LVDT Extensometer

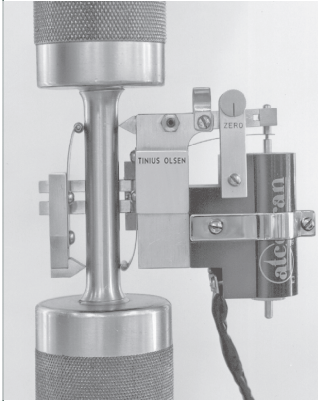

Averaging - In this type of extensometer, knife edges are placed on opposite sides of the specimen to provide an average amount of strain between the two gage points.

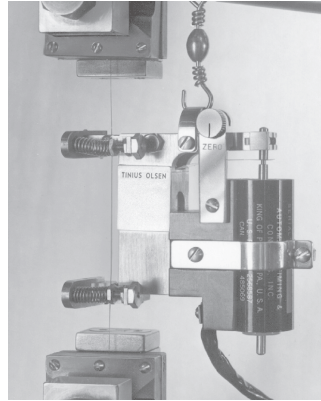

Film clamps - These spring activated clamps allow precise strain measurement of thin materials up to 0.125in/3mm thick, including plastics and foils, without marring the specimen. Note that this option is only available for non-averaging extensometers and typically requires the use of a counterbalance to support the extensometer.

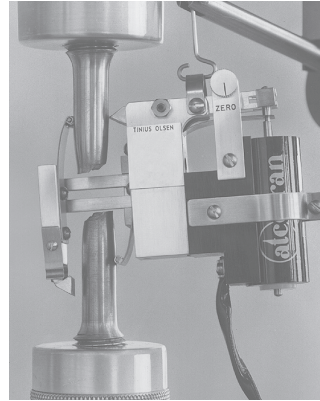

Breakaway Release - This option is ideally used when measuring strain on samples with brittle characteristics and which may cause premature failure. This option typically requires the use of a counterbalance to support the extensometer and is available for both averaging and nonaveraging type extensometers.

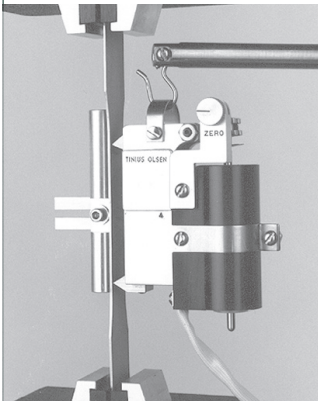
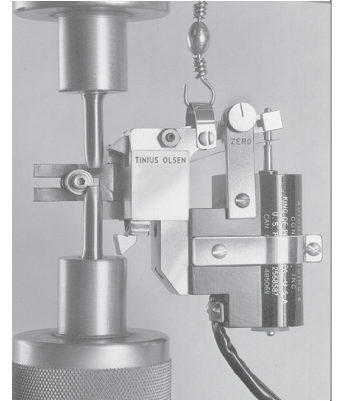

Sheet Metal Attachment - This option allows the extensometer to accommodate thin, flat specimens. Note that this option is only available for non-averaging extensometers and typically requires the use of a counterbalance to support the extensometer.

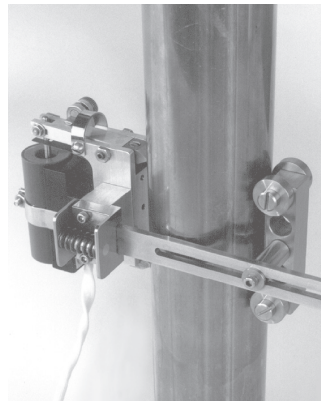

Extension Bracket - This option allows the extensometer to be used with samples that are thicker than maximum opening of 0.625in/16mm on the standard model. There are three choices with this option where an extension bracket allows the extensometer to be mounted on samples that are either 1in/25mm, 2in/50mm or 3in/75mm thick. Note that this option is only available for non-averaging extensometers.

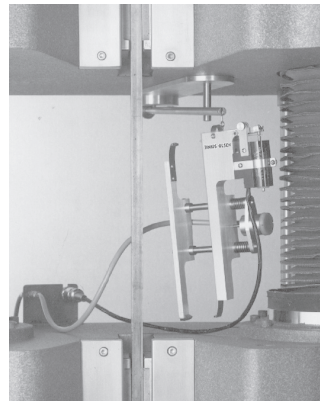

Pneumatic Release - This option is combined with a swing away support and allows the remote release of the extensometer from the sample.

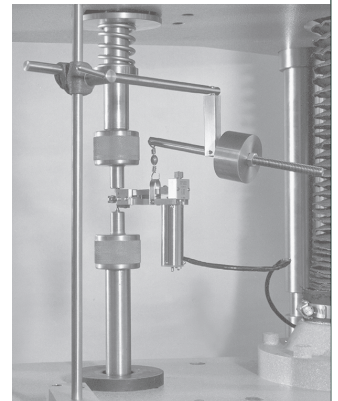

Counterbalance Support - This option is used to support the extensometer and is commonly used when the extensometer is attached to small or fragile samples.